



DESIGN NOTES

SOT-23 SMBus Fan Speed Controller Extends Battery Life and Reduces Noise – Design Note 238

David Canny

Introduction

Battery run times for notebook computers and other portable devices can be improved and acoustic noise reduced by using Linear Technology's LTC[®]1695 to optimize the operation of these products' internal cooling fans. The LTC1695 comes in a SOT-23 package and provides all the functions necessary for a system controller or microcontroller to regulate the speed of a typical 5V/≤1W fan via a 2-wire SMBus interface.

By varying the fan speed according to the system's instantaneous cooling requirements, the power consumption of the cooling fan is reduced and battery run times are improved. Acoustic noise is practically eliminated by operating the fan below maximum speed when the thermal environment permits. Designers also have the option of controlling the temperature in portable devices by using feedback from a temperature sensor to control the fan speed.

Figure 1 shows a typical application. Fan speed is easily programmed by sending a 6-bit digital code to the LTC1695 via the SMBus. This code is converted into an analog reference voltage that is used to regulate the output voltage of the LTC1695's internal linear regulator. The system controller can enable an optional boost feature

that eliminates fan start-up problems by outputting 5V to the fan for 250ms before lowering the output voltage to its programmed value. Another important feature is that the system controller can read overcurrent and overtemperature fault conditions from information stored in the LTC1695. The part's SMBus address is hard-wired internally as 1110100 (MSB to LSB, A6 to A0) and the data code bits D0 to D6 are latched at the falling edge of the SMBus Data Acknowledge signal (D6 is a Boost-Start Enable bit and D5 to D0 translate to a linearly proportional output voltage, 00–3F hex = 0V–5V). The LTC1694, which also appears in Figure 1, is a dual SMBus accelerator/pull-up device that may be used in conjunction with the LTC1695. Table 1 lists some 5V brushless DC fans suitable for typical LTC1695 fan speed control applications.

Boost-Start Timer, Thermal Shutdown and Overcurrent Clamp Features

A DC fan typically requires a starting voltage higher than its minimum stall voltage. For example, one Micronel 5V fan requires a 3.5V starting voltage, but once started, it will run until its terminal voltage drops below 2.1V (its stall voltage). Thus, the user must ensure that the fan starts up properly before programming the fan voltage to

Ⓜ, LTC and LT are registered trademarks of Linear Technology Corporation.

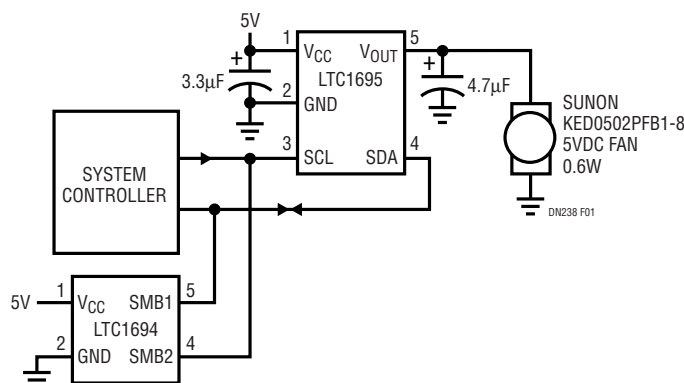

Figure 1. SMBus Fan Speed Controller

a value that is lower than the starting voltage. Monitoring the fan's DC current for stall conditions does not help because some fans consume almost the same amount of current at the same terminal voltage in both stalled and operating conditions. Another approach is to detect the absence of fan commutation ripple current. However, this is complex and requires customization for the characteristics of each brand of fan. The LTC1695 offers a simple and effective solution through the use of a boost-start timer. By setting the Boost-Start Enable bit high via the system controller, the LTC1695 outputs 5V for 250ms to the fan before lowering the voltage to its programmed value (see Figure 2 for the start-up voltage profile).

During a system controller Read command, bits 6 and 7 in the data byte code are defined as the Thermal Shutdown Status (THE) and the Overcurrent Fault (OCF), respectively. The remaining bits of the data byte (0 to 5) are set low during host read back. The LTC1695 shuts down its PMOS pass transistor and sets the THE bit high if die

junction temperature exceeds 155°C. During an overcurrent fault, the LTC1695's overcurrent detector sets the OCF bit high and actively clamps the output current to 390mA. This protects the LTC1695's PMOS pass transistor. Under dead short conditions ($V_{OUT} = 0$), although the LTC1695 clamps the output current, the large amount of power dissipated on the chip will force the LTC1695 into thermal shutdown. These dual protection features protect both the IC and the fan, but more importantly, alert the host to system thermal management faults. During a fault condition, the SMBus logic continues to operate so that the host can poll the fault status data.

Conclusion

The LTC1695 improves battery run times and reduces acoustic noise in portable equipment. In addition, it provides important performance and protection features by controlling the operation of the equipment's cooling fan. It comes in a SOT-23 package and is easily programmed via the SMBus interface.

Table 1. Some 5V DC Fans' Characteristics

MANUFACTURER	PART NUMBER	AIRFLOW (CFM)	POWER (W)	SIZE (L • W • H)mm ³
SUNON	KDE0501PFB2-8	0.65	0.50	20 • 20 • 10
ATC	AD0205HB-G51	0.80	0.45	25 • 25 • 10
SUNON	KDE0502PFB2-8	1.70	0.60	25 • 25 • 10
SUNON	KDE0503PFB2-8	3.20	0.60	30 • 30 • 10
SUNON	KDE0535PFB2-8	4.80	0.70	35 • 35 • 10
Micronel	F41MM-005XK-9	6.10	0.70	40 • 40 • 12

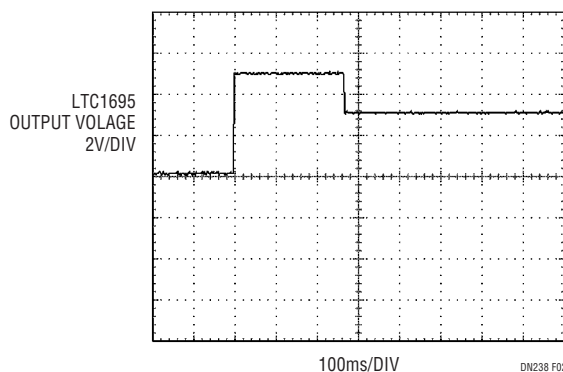

Figure 2. Fan Start-Up Voltage Profile

Data Sheet Download

<http://www.linear-tech.com/go/dnLTC1695>

For literature on our Controllers, call **1-800-4-LINEAR**. For applications help, call (408) 432-1900, Ext. 2681